TOSVERT VF-S15

Functions for lift application Instruction Manual

- Contents -

1. Introduction	2
2. Functions	2
3. Light –load high-speed operation function.....	3
3.1 Related parameters.....	3
3.2 Mode description.....	4
3.2.1 Automatic setting mode of high-speed operation speed ($F\ 3\ 2\ 8=1, 2$).....	6
3.2.2 Fixed setting mode of high-speed operation speed ($F\ 3\ 2\ 8=3, 4$).....	8
3.3 How to adjust parameters	10
3.3.1 Automatic setting mode of high-speed operation speed ($F\ 3\ 2\ 8=1, 2$).....	10
3.3.2 Fixed setting mode of high-speed operation speed ($F\ 3\ 2\ 8=3, 4$).....	12
3.3.3 Frequency switching Acceleration/deceleration at light load ($F\ 3\ 3\ 9$).....	13
4. Brake sequence functions.....	14
4.1. Standard connection for lift application	14
4.2 Parameter adjustment procedure for brake sequence function	15
4.3 Setting sample of related parameters.....	16
4.4 Brake sequence function.....	18
4.4.1 Parameters for brake sequence functions	19
4.4.2 Execution of "Brake time learning".....	22
4.4.3 Brake timing with maximum load.....	23
4.4.4 Abnormal phenomenon and the measures	24

1. Introduction

TOSVERT VF-S15 has effective functions for lift application.

This instruction manual explains the light-load high-speed operation function and the brake sequence function of VF-S15 for crane and hoists applications.

<Note>

This instruction manual mentions factory specific coefficient parameters.

2. Functions

VF-S15 has the following functions for lift application.

Use of vector control is based on the execution of brake sequence function or light-load high-speed operation. Therefore, set $P11$ (Torque boost setting macro function) = 2 (Vector control + auto-tuning), or set motor related parameters, $F410$ - $F417$, and $P1$ (V/F control mode selection) = 3 (Vector control).

1) Light-load high-speed operation function

This function enhances the operating efficiency of the machine by increasing the rotational speed of the motor in case of light load operation.

This function is useful for lifts and material handling applications which repeatedly drive light and heavy loads.

The learning function of VF-S15 simplifies the adjustment of light-load high-speed operation, just to execute the forward run (up) or reverse run (down) operation. ($F328=3, 4$ only)

2) Brake sequence function

To ensure smooth operation, the motor produces enough torque before the brake is released.

The learning function for brake timing simplifies rough adjustment of creeping frequency, creeping time and brake release time.

3. Light –load high-speed operation function

3.1 Related parameters

Title	Communication No.	Function	Adjustment range	Minimum setting unit (Panel/Communication)	Default setting
<i>F327</i>	0327	Offset of light load measurement torque	0-2000 (%)	-	1000
<i>F328</i>	0328	Light-load high-speed operation selection	0:Disabled 1: High-speed operation speed set automatically (Power running at F command: Increase) 2: High-speed operation speed set automatically (Power running at R command: Increase) 3: High-speed operation speed set with <i>F330</i> (Power running at F command: Increase) 4: High-speed operation speed set with <i>F330</i> (Power running at R command: Increase)	-	0
<i>F329</i>	0329	Light-load high-speed learning function	0:No learning 1:Forward run learning 2:Reverse run learning	-	0
<i>F330</i>	0330	Automatic light-load high-speed operation frequency	30.0 - ω_L (Hz)	0.1/0.01	(*1)
<i>F331</i>	0331	Light-load high-speed operation switching lower limit frequency	5.0 - ω_L (Hz)	0.1/0.01	40.0
<i>F332</i>	0332	Light-load high-speed operation load waiting time	0.0 - 10.0 (s)	0.1/0.1	0.5
<i>F333</i>	0333	Light-load high-speed operation load detection time	0.0 - 10.0 (s)	0.1/0.1	1.0
<i>F334</i>	0334	Light-load high-speed operation heavy load detection time	0.0 - 10.0 (s)	0.1/0.1	0.5
<i>F335</i>	0335	Switching load torque during power running	-250 - 250%	1/0.01	50
<i>F336</i>	0336	Heavy-load torque during power running	-250 - 250%	1/0.01	100
<i>F337</i>	0337	Heavy-load torque during constant power running	-250 - 250%	1/0.01	50
<i>F338</i>	0338	Switching load torque during regenerative braking	-250 - 250%	1/0.01	50
<i>F339</i>	0339	Frequency switching Acceleration/deceleration at light load	0 - ω_L (Hz)	0.1/0.01	0.0

(*1) Default setting values vary depend on the setup menu setting.

Note 1: Parameters *F335* to *F338* need adjustment according to the load.

The learning function of VF-S15 simplifies the adjustment of light-load high-speed operation, just to execute the forward run (up) or reverse run (down) operation. (*F328*=3, 4 only)

Note 2: If the judgment whether or not switching to light-load high-speed operation differs from when the motor is cold and when the motor is hot, set the value of *F327* larger. Usually, it is set with the default setting value.

Note 3: When operating light-load high-speed operation, use vector control. Set *RU2* (Torque boost setting macro function) =2 (Vector control + auto-tuning), or set motor related parameters *F410* to *F417*, and *P1* (V/F control mode selection) =3 (Vector control).

3.2 Mode description

The light-load high-speed operation includes the modes below:

Each mode can be set by the light-load high-speed operation selection (*F 328*).

Title/function	Default setting	Action
<i>F 328</i> Light-load high-speed operation selection	0: Disabled	Light-load high-speed operation disabled.
	1:High-speed operation speed set automatically (Power running at F command: Increase)	When inverter judges to be light-load, the high-speed operation frequency is automatically set according to a detected torque.
	2:High-speed operation speed set automatically (Power running at R command: Increase)	
	3:High-speed operation speed set with <i>F 330</i> (Power running at F command: Increase)	When inverter judges to be light-load, the operation is set to the automatic light-load high-speed operation frequency (<i>F 330</i>).
	4:High-speed operation speed set with <i>F 330</i> (Power running at R command: Increase)	

Example: If automatic setting mode of high-speed operation speed is used,

set *F 328* to 1 for F (forward command): Up

set *F 328* to 2 for R (reverse command): Up

Note: Light load output and Heavy load output conditions of output terminal functions are different according to *F 328* setting.

1) *F 328* (Light-load high-speed operation selection) =0

Light load output (Function No. 106/107):
ON: The absolute value of the detected torque is under the absolute value of <i>F 335</i> (Switching load torque during power running)
Light load output (Function No. 164/165):
ON: The absolute value of the detected torque is under the absolute value of <i>F 335</i> (Switching load torque during power running)
Heavy load output (Function No. 108/109):
ON: The absolute value of the detected torque is the absolute value of <i>F 337</i> (Heavy-load torque during constant power running) or more

Note) Function No. 106/107 and No.164/165 are same action when *F 328*=0. Each action is different when *F 328* setting is not 0.

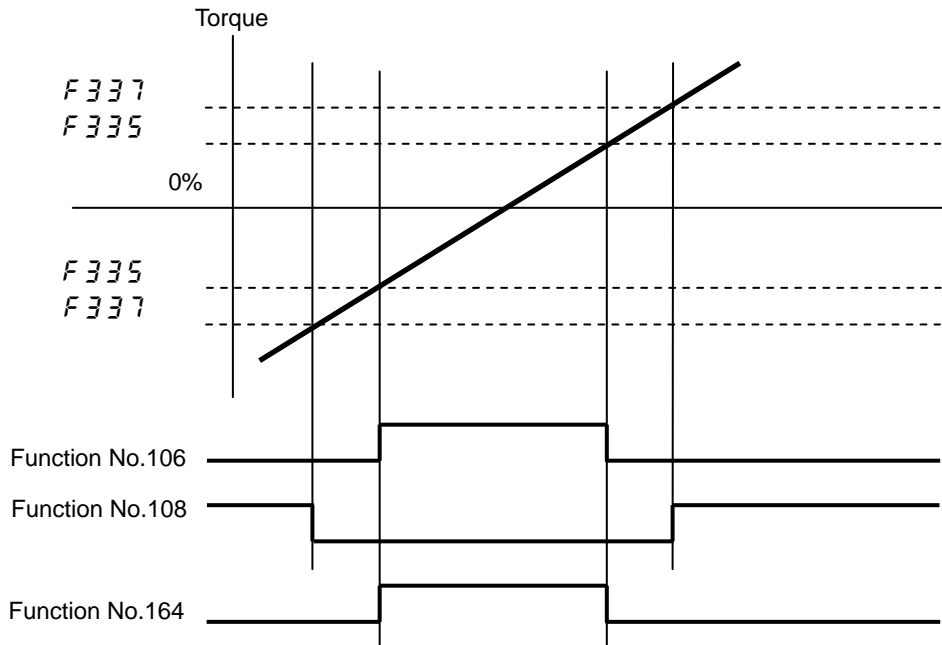

2) *F328* (Light-load high-speed operation selection) setting is not 0

Light load output (Function No. 106/107)
 ON: The inverter judges that the light-load high-speed operation is possible during light-load judgment time, and heavy-load is not detected during light-load high-speed operation. When HSSL (Light-load high-speed operation prohibitive signal) is ON before light-load high-speed operation, light-load output is not ON while HSSL is ON.

Light load output (Function No. 164/165)
 ON: The inverter judges that the light-load high-speed operation is possible during light-load judgment time, and heavy-load is not detected during light-load high-speed operation. The signal is not dependent on HSSL (Light-load high-speed operation prohibitive signal).

Heavy load output (Function No. 108/109)
 ON: When heavy-load is detected.

HSSL =OFF

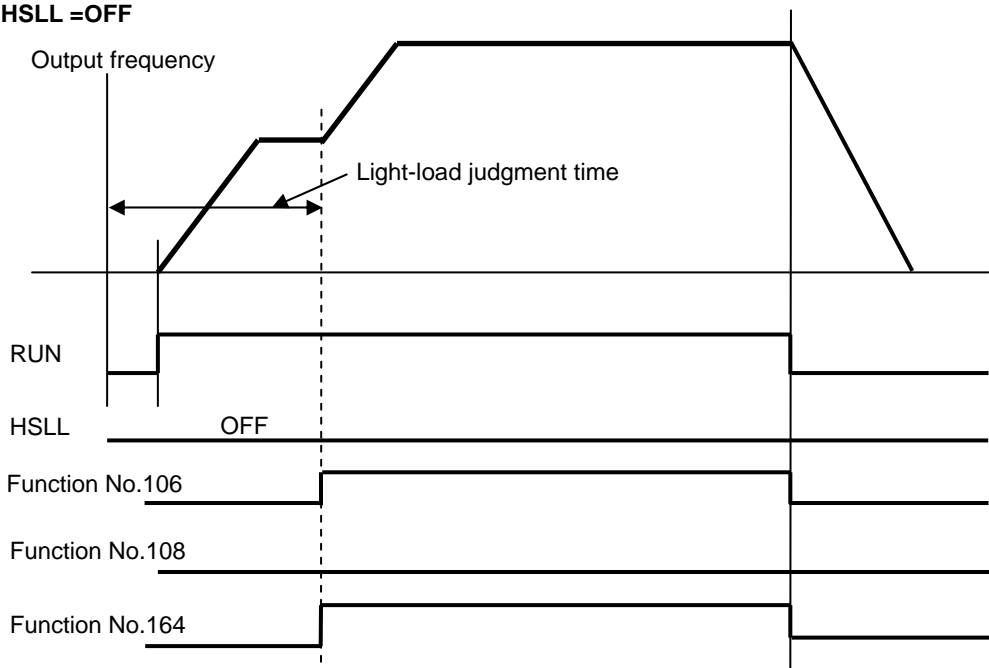

HSSL =OFF->ON->OFF

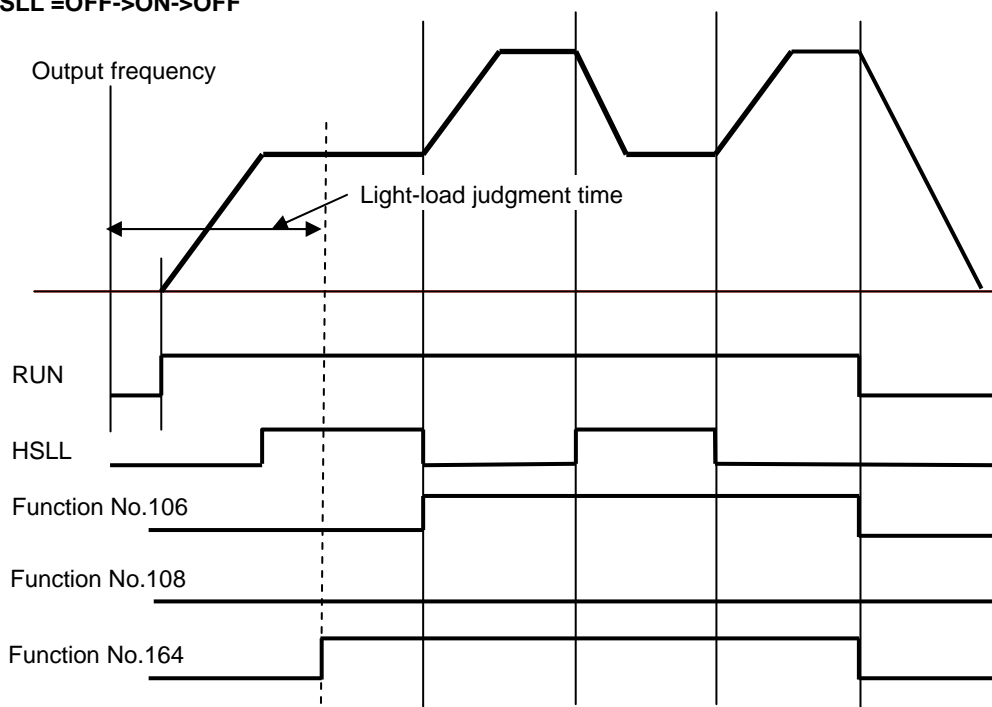

3.2.1 Automatic setting mode of high-speed operation speed (F328=1, 2)

The diagram on the next page (Fig.1) is the timing chart when the automatic setting mode of high-speed operation speed (F328=1) is applied to lift application.

At the operation frequency of the light-load high-speed operation switching lower limit frequency (F331) or more (point A in the Fig.1), if a detected torque (*1) after reaching the set speed is the switching load torque during power running (F335 setting value) or less, the inverter judges that the load is light.

For light-load operation, the frequency decided with the following formula is determined as a target frequency (high-speed operation frequency) and the operation is accelerated toward the target frequency. (Point B in the Fig.1 Light-load high-speed operation)

$$\text{Target frequency} = (\text{Value set with F335}) \times [\text{Base frequency (UL)}] / (\text{The detected torque})$$

when target frequency \leq UL (\leq FH)

(*1) Average torque during light-load high-speed operation load detection time (F333) after light-load high-speed operation load detection waiting time (F332) (5% or more)

Light-load detection is carried out after reaching the set speed and when an operation frequency is the light-load high-speed operation switching lower limit frequency (F331) or more.

When reaching the conditions below, the light-load high-speed operation is canceled and the operation is returned to the operation at the frequency of speed command value.

- 1) The detected torque exceed the following the judgment value during acceleration up to the high-speed operation frequency.
The detected torque (*1) + (Heavy-load torque during power running (F336) – Switching load torque during power running(F335))(0% or more)
- 2) The detected torque exceed the following the judgment value after reaching the target frequency and after a lapse of the light-load high-speed operation heavy load detection time (F334).
The detected torque (*1) + (Heavy-load torque during constant power running (F337) – Switching load torque during power running (F335) (0% or more))
- 3) The speed command value under the light-load high-speed operation switching lower limit frequency (F331) is entered.
- 4) The Light-load high-speed operation prohibitive signal is ON.

《Example of operation》 Light-load high-speed operation selection
 (F 3 2 8 = 1: High-speed operation speed set automatically): F (Up)

Light-load high-speed operation

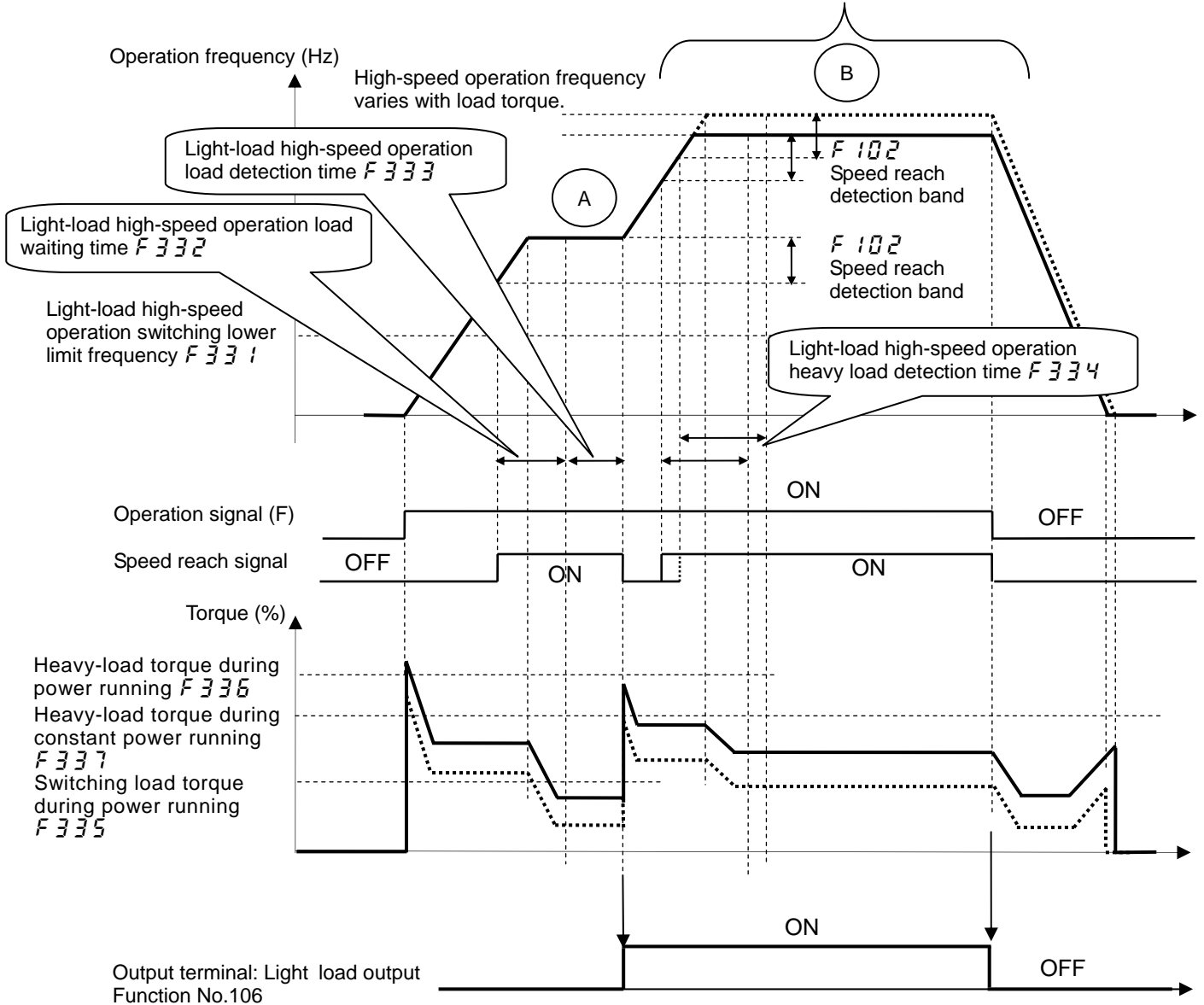

Fig.1

3.2.2 Fixed setting mode of high-speed operation speed (F328=3, 4)

The diagram on the next page (Fig.2) is the timing chart when fixed setting mode of the high-speed operation speed (F328=3) is applied to lift application.

At the operation frequency of the light-load high-speed operation switching lower limit frequency (F331) or more (point A in the Fig.2), if an average torque during the light-load high-speed operation load detection time (F333) after reaching the set speed and after a lapse of the light-load high-speed operation load detection waiting time (F332) is under the switching load torque during power running (F335), the inverter judges that light-load is detected and accelerates up to an automatic light-load high-speed operation frequency (F330). (Point B in the Fig.2 Light-load high-speed operation)

Load torque detection is carried out when an operation frequency is the light-load high-speed operation switching lower limit frequency (F331) or more and after reaching the set speed.

When reaching the conditions below, the light-load high-speed operation is canceled and the operation is returned to the operation at the frequency of speed command value.

- 1) The torque is exceeded the heavy-load torque (F336) during acceleration up to the automatic light-load high-speed operation frequency (F330).
- 2) The torque is exceeded the heavy-load torque during constant power running (F337) after reaching the automatic light-load high-speed operation frequency (F330) and after a lapse of the light-load high-speed operation heavy load detection time (F334).
- 3) The speed command value under the light-load high-speed operation switching lower limit frequency (F331) is entered.
- 4) The Light-load high-speed operation prohibitive signal is ON.

《Example of operation》 Light-load high-speed operation selection
 (F 328=3: High-speed operation set with F 330): F (Up)

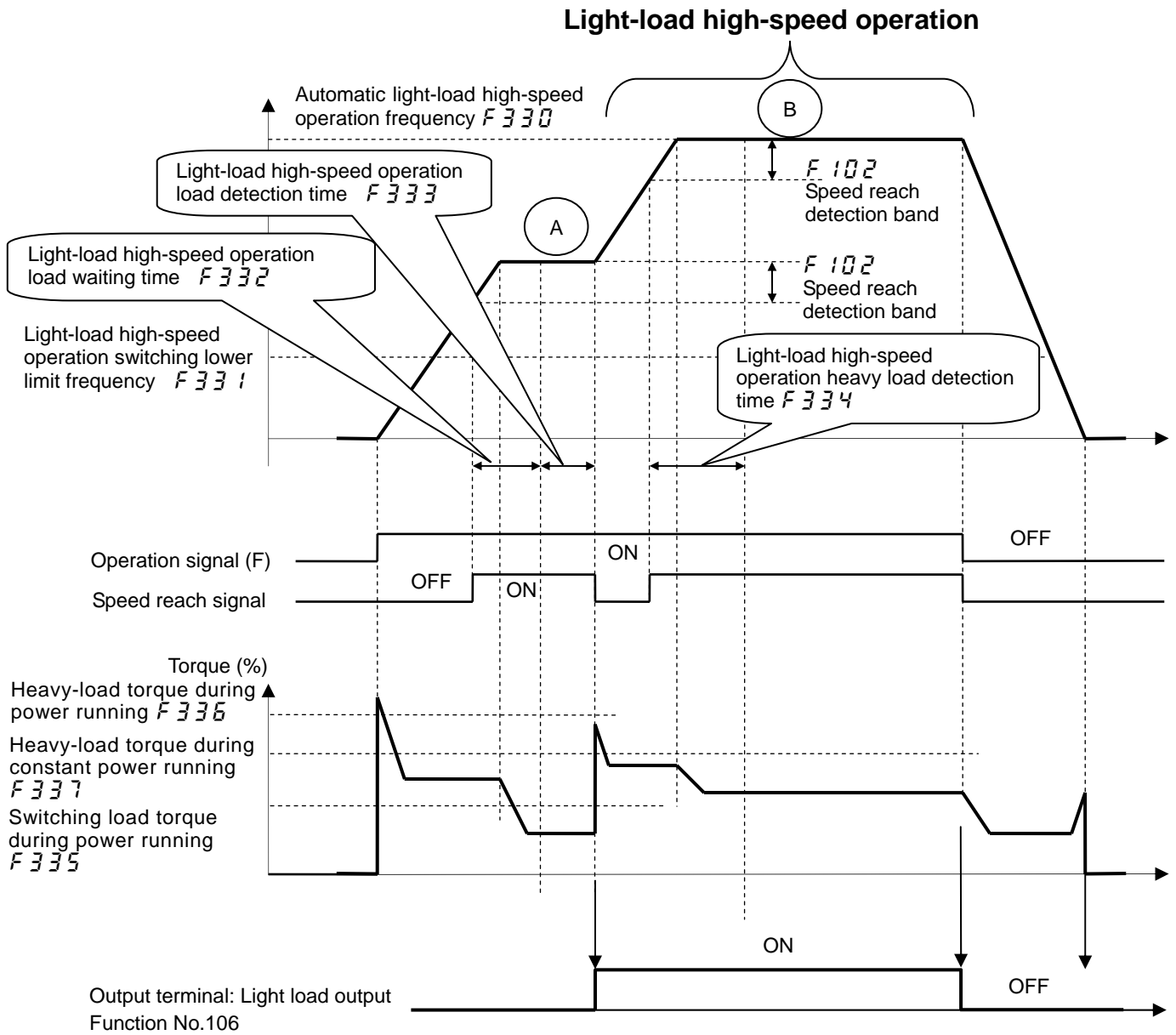

Fig.2

3.3 How to adjust parameters

If the light-load high-speed operation is used, be sure to set the motor-related parameters (Motor constants).

Refer to Section 6.25 of VF-S15 instruction manual (E6581611) to set motor-related parameters.

In addition, for the high-speed operation fixed setting mode ($F328=3, 4$), learning function simplifies the adjustment of the light-load high-speed operation.

3.3.1 Automatic setting mode of high-speed operation speed ($F328=1, 2$)

《Adjustment method for lift application》

When the light-load high-speed operation is carried out with normal operation of 60Hz, follow the procedure below:

- 1) Set the parameter below at an arbitrary position of the status monitor display selection ($F711$ to $F718$).

Torque monitor	Set value 7	Ex. of LED display	9 20
----------------	-------------	--------------------	------
- 2) Set $F328=0$ to avoid switching to the light-load high-speed operation.
- 3) Check the torque monitor value of the following conditions and set the value.
Use the maximum load which allows light-load high-speed operation.

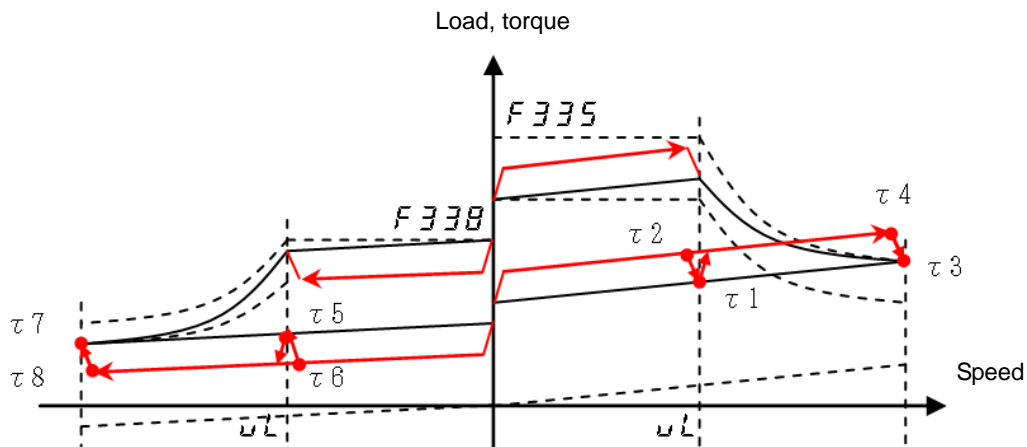

Lifting (Up): Power running operation

- τ1: steady torque at base frequency (ω_L)
- τ2: maximum torque during acceleration up to base frequency (ω_L) operation
- τ3: steady torque at light-load high-speed frequency operation (upper limit frequency ($\omega_{L'}$))
- τ4: maximum torque during acceleration up to light-load high-speed frequency operation (upper limit frequency ($\omega_{L'}$))

Lowering (down): Regenerative braking operation

- τ5: steady torque at base frequency (ω_L)
- τ6: minimum torque during acceleration up to base frequency (ω_L) operation
- τ7: steady torque at light-load high-speed frequency operation (upper limit frequency ($\omega_{L'}$))
- τ8: minimum torque during acceleration up to light-load high-speed frequency operation (upper limit frequency ($\omega_{L'}$))

*τ6 and τ8 are for reference.

Set the value of corresponding parameters after each operation is checked.

- (1) Setting of F_{337} (Heavy-load torque during constant power running)
Calculate F_{337} by the torque value τ_3 .

$$F_{337} = \tau_3 \times \omega_L / \omega_L$$

- (2) Setting of F_{335} (Switching load torque during power running)
Calculate F_{335} by F_{337}

$$F_{335} = F_{337} - \text{Max}(\tau_3 - \tau_1, 5\%)$$

- (3) Setting of F_{336} (Heavy-load torque during power running)
Calculate F_{336} by F_{337}

$$F_{336} = F_{337} - \text{Max}(\tau_4 - \tau_3, 5\%)$$

- (4) Setting of F_{338} (Switching load torque during regenerative braking)
Calculate F_{338} by the torque value τ_7 and τ_5 .

$$F_{338} = (\tau_7 + \text{Max}(\tau_5 - \tau_7, 5\%)) \times \omega_L / \omega_L$$

<Example>

$$\omega_L = 120\text{Hz}, \omega_L = 60\text{Hz}$$

$$\tau_1 = 30\%, \tau_2 = 40\%, \tau_3 = 40\%, \tau_4 = 50\%$$

$$F_{337} = 40\% \times 120\text{Hz}/60\text{Hz} = 80\%$$

$$F_{335} = 80\% - \text{Max}(40\% - 30\%, 5\%) = 70\%$$

$$F_{336} = 80\% + \text{Max}(50\% - 40\%, 5\%) = 90\%$$

$$\tau_5 = 15\%, \tau_6 = 5\%, \tau_7 = 10\%, \tau_8 = 0\%$$

$$F_{338} = (10\% + \text{Max}(15\% - 10\%, 5\%)) \times 120\text{Hz}/60\text{Hz} = 30\%$$

Change F_{335} and F_{338} values little by little in order not to switch to the light-load high-speed operation.

Change F_{336} and F_{337} values by the above changing.

The judgment value of heavy-load during acceleration of the power running is the value that added the detected torque during operation at the light-load high-speed operation switching lower limit frequency (F_{331}) or more and the value $F_{336} - F_{335}$.

The detected torque + (Heavy-load torque during power running (F_{336}) – Switching load torque during power running (F_{335})) (0% or more)

The judgment value of heavy-load during constant power running is the value that added the detected torque during operation at the light-load high-speed operation switching lower limit frequency (F_{331}) or more and the value of $F_{337} - F_{335}$.

The detected torque + (Heavy-load torque during constant power running (F_{337}) – Switching load torque during power running (F_{335})) (0% or more)

- 4) When reaching a state where the inverter will not switch to the light-load high-speed operation, check that a high-speed operation frequency changes according to the change of load.
- 5) Restore the parameter changed in 1) to the initial value. ($F_{711} \sim F_{718}$)
If checking the torque with the monitor, there is no need to restore the initial value even after the parameters are adjusted.

3.3.2 Fixed setting mode of high-speed operation speed (F328=3, 4)

《Adjustment method using the learning function for lift application》

When the light-load high-speed operation is carried out with normal operation of 60Hz, follow the procedure below:

- 1) Set the automatic light-load high-speed operation frequency (F330). Ex.: F330=90Hz
- 2) Set the light-load high-speed learning function (F329) to 1 (Forward run learning).
- 3) Carry out the 60Hz-lifting (forward power running) operation while hanging the maximum load which allows light-load high-speed operation and check that the operation switches to the light-load high-speed operation (90Hz operation). (Forward run learning)
During the learning operation, $\frac{L}{U}n$ blinks on the left side of the frequency display LED.
- 4) Set the light-load high-speed learning function (F329) to 2 (Reverse run learning).
- 5) Similarly, carry out the 60Hz-lowering (reverse regenerative braking) operation while hanging the maximum load which allows light-load high-speed operation and check that the operation switches to the light-load high-speed operation (90Hz operation).
During the learning operation, $\frac{L}{U}n$ blinks on the left side of the frequency display LED.
- 6) The following parameters are automatically adjusted by carrying out operations in 3) and 5).

Title	Function	Default setting
F335	Switching load torque during power running	50
F336	Heavy-load torque during power running	100
F337	Heavy-load torque during constant power running	50
F338	Switching load torque during regenerative braking	50

- 7) Hang the minimum load which does not allow light-load high-speed operation and check that a normal operation does not switch to either lifting (power running) or lowering (regenerative braking) operations.
- 8) In case of a dynamic lift off at lifting (power running) operation, carry out the dynamic lift off after high-speed operation and check that the inverter operates at the normal speed.

《Cautions》

- If the result of learning operation is as follows, the learning operation is completed when it stops without transition to the high-speed operation.
 - Switching load torque during power running (F 335) is 70% or more
 - Switching load torque during regenerative braking (F 338) is 70% or more
- If a detected torque is 150% or more during acceleration of the high-speed operation, the high-speed operation stops and the learning operation is completed without reflecting the learning data.
- If a detected torque is 100% or more during constant speed operation after completing the acceleration of the high-speed operation, the high-speed operation stops and the learning operation is completed without reflecting the learning data.
- Do not change the frequency command value, acceleration time, direction of rotation and related parameters, and not input the light-load high-speed operation prohibitive signal before the learning operation is completed.
The learning operation may not complete correctly.
- “ L n 2 ” means that the learning operation is impossible.
 - F 331 > F 330
 - F 328 = 1 or 2
 - Operation frequency < F 331
 - Acceleration time > 100s
 - Direction of rotation is opposite of F 329 setting
 - The light-load high-speed operation prohibitive signal is ON
 If the reflecting the learning data is completed, “ L n 2 ” is not displayed.
- “ L n 2 ” may be displayed when the inverter starts because of the torque control at the start. Normal if “ L n 2 ” disappears after output frequency reaches F 331 or more.
- “ L n 3 ” is displayed when the inverter detect heavy load.

3.3.3 Frequency switching Acceleration/deceleration at light load (F 339)

During light-load high-speed operation, if operation frequency exceeds frequency switching acceleration/ deceleration at light load (F 339), switch acceleration/ deceleration time to acceleration/ deceleration time 2 (F 500, F 501).

Acceleration/ deceleration time 3 (F 510, F 511) has priority over frequency switching Acceleration/ deceleration at light load.

In addition, this function is reset with the following conditions;

- Operation frequency reached the set speed (reached to the set frequency)
- After switching forward/ reverse operation (switching from forward to reverse operation, or conversely)
- After the inverter stopped

4. Brake sequence functions

4.1. Standard connection for lift application

<SINK logic>

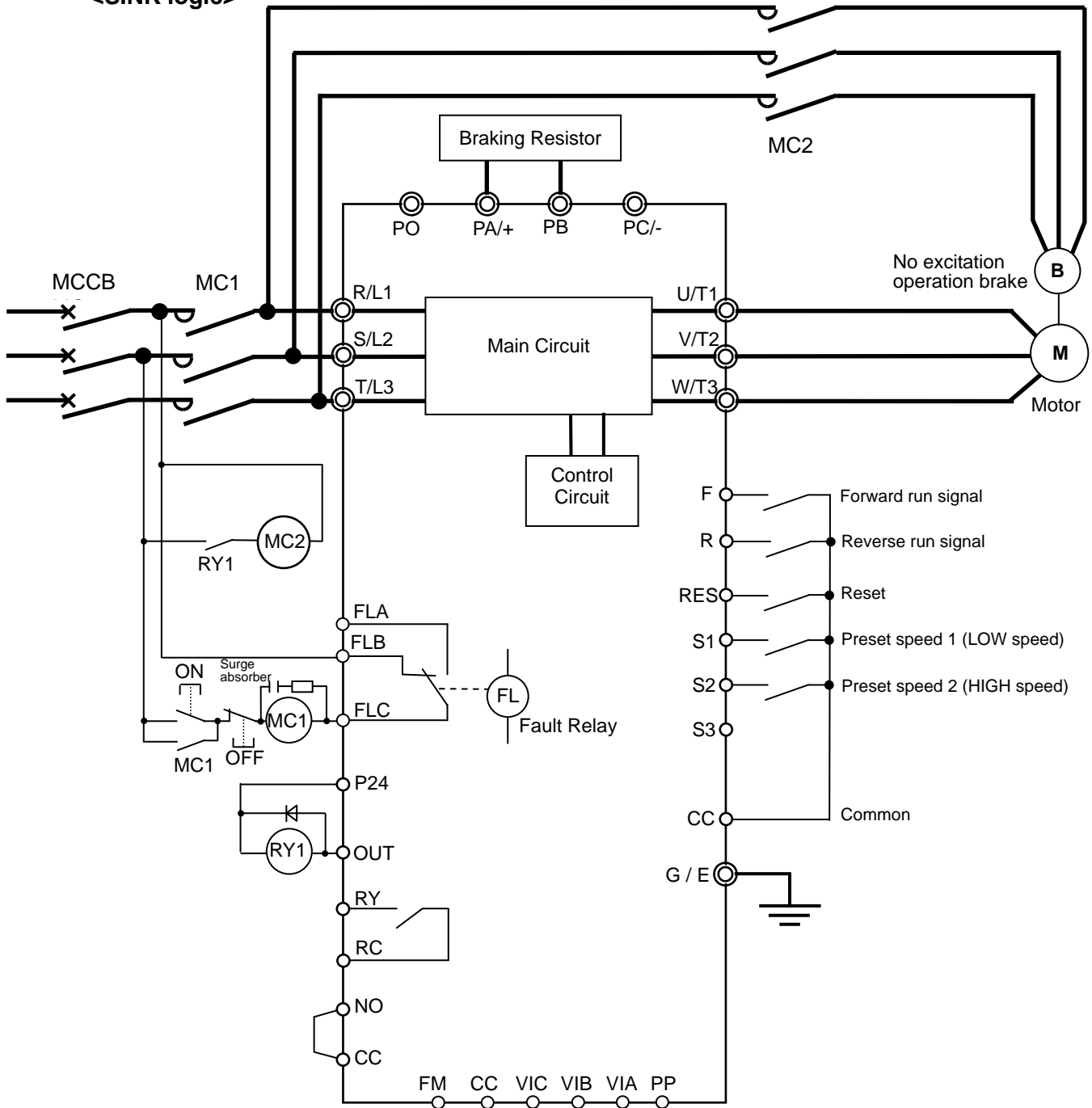

[Operation] By terminal block

[Speed reference] Preset speed 1 and 2, Operation panel

4.2 Parameter adjustment procedure for brake sequence function

Set $F450$ and $F452$ following to the table mentioned in 4.3 prior to use brake sequence function,

Set related parameters such as $Cn0d$, $Fn0d$.

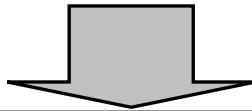

Set vector control parameters (motor constant value) by executing the auto-tuning functions without load.

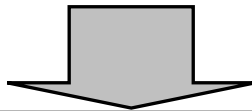

Execute the brake timing learning function without load to roughly adjust the brake ON/OFF timing.
If brake is not active at switching forward/ reverse operation, adjust speed reference filter coefficient ($F452$).

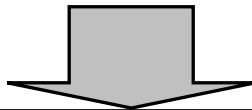

Operate lifting (forward)/lowering (reverse) run with maximum load, and confirm that there is no trouble like 'inverter trip' or 'luggage shifts'.

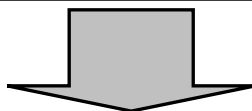

If 'inverter trip' or 'luggage shifts' occurs, adjust parameters for brake sequence function.

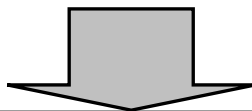

Completion

4.3 Setting sample of related parameters

Title	Comm. Number	Functions	Setting range	Minimum setting value (Panel/Comm.)	Default value	Setting sample	Notes
<i>EN0d</i>	0003	Command mode selection	0 - 4	-	1	0	0:Terminal input enabled
<i>FN0d</i>	0004	Frequency setting mode selection 1	0 - 14	-	0	3	3:Setting dial 2
<i>RE1</i>	0009	Acceleration time 1	0.0 - 3600 (s)	0.1/0.1	10.0	1.0	
<i>dEL</i>	0010	Deceleration time 1	0.0 - 3600 (s)	0.1/0.1	10.0	1.0	
<i>FH</i>	0011	Maximum frequency	30.0 - 500.0(Hz)	0.1/0.01	80.0	60.0	
<i>UL</i>	0012	Upper limit frequency	0.5 - <i>FH</i> (Hz)	0.1/0.01	(*1)	60.0	
<i>LL</i>	0013	Lower limit frequency	0.0 - <i>UL</i> (Hz)	0.1/0.01	0.0	6.0	
<i>Pt</i>	0015	V/F control mode selection	0 - 8	-	(*1)	3 (*3)	3: Vector control
<i>5r1</i>	0018	Preset speed operation frequency 1	<i>LL</i> - <i>UL</i>	0.1/0.01	0.0	10.0	Operation frequency (Low)
<i>5r2</i>	0019	Preset speed operation frequency 2	<i>LL</i> - <i>UL</i>	0.1/0.01	0.0	60.0	Operation frequency (High)
<i>F131</i>	0131	Output terminal selection 2A (OUT)	0 - 255	-	6	68	68: Brake release signal (*3)
<i>F240</i>	0240	Starting frequency	0.1 - 10.0 (Hz)	0.1/0.01	0.5	0.5	
<i>F304</i>	0304	Dynamic braking selection	0 - 4	-	0	1	1:Enabled (Resistor overload protection enabled)
<i>F305</i>	0305	Overvoltage limit operation (Deceleration stop mode selection)	0 - 3	-	2	2 (*4)	1:Disabled 2:Enabled (quick deceleration)
<i>F308</i>	0308	Dynamic braking resistance	1.0 - 1000 ohm	0.1/0.1	(*2)	(*5)	
<i>F309</i>	0309	Dynamic braking resistor capacity	0.01 - 30.00kW	0.01/0.01	(*2)	(*6)	
<i>F325</i>	0325	Brake releasing waiting time	0.00-2.50 (s)	0.01/0.01	0.00	0.00	
<i>F326</i>	0326	Brake releasing small current detection level	0-100 (%)	1/1	0	0	
<i>F340</i>	0340	Creeping time 1	0.00 - 10.00 (s)	0.01/0.01	0.00	0	Refer to section 4.4.
<i>F341</i>	0341	Braking mode selection	0 - 3	-	0	1	
<i>F342</i>	0342	Load portion torque input selection	0 - 4	-	4	4	
<i>F343</i>	0343	Hoisting torque bias input (valid only when <i>F342</i> =4)	-250 - 250%	1/0.01	100	100	
<i>F344</i>	0344	Lowering torque bias multiplier	0 - 100%	1/0.01	100	60	
<i>F345</i>	0345	Brake release time	0.00 - 10.00 (s)	0.01/0.01	0.05	0.05	
<i>F346</i>	0346	Creeping frequency	<i>F240</i> - 20.0Hz	0.1/0.01	3.0	3.0	
<i>F347</i>	0347	Creeping time 2	0.00 - 10.00 (s)	0.01/0.01	0.10	0.10	
<i>F348</i>	0348	Braking time learning function	0, 1	-	0	1	
<i>F400</i>	0400	Auto-tuning	0 - 5	-	0	(*3)	Refer to of the VFS15 instruction manual (E6581611 : section 6.1.5 or 625)
<i>F401</i>	0401	Slip frequency gain	0 - 250(%)	1/1	70		
<i>F402</i>	0402	Automatic torque boost value	0.1 - 30.0(%)	0.1/0.1	(*2)		
<i>F405</i>	0405	Motor rated capacity	0.01 - 22.00kW	0.01/0.01	(*2)		
<i>F415</i>	0415	Motor rated current	0.1 - 100.0A	0.1/0.1	(*2)		
<i>F417</i>	0417	Motor rated speed	100 - 64000min ⁻¹	1/1	(*1)		
<i>F452</i>	0452	Power running stall continuous trip detection time	0.00 - 10.00 (s)	0.01/0.01	0.00	0.5(*7)	
<i>F460</i>	0460	Speed loop gain	0.0: Auto 0.1-25.0	-	0.0	5.0	Setting is necessary at the use of brake sequence function.
<i>F462</i>	0462	Speed reference filter coefficient	0-100	-	35	20 (*8)	Setting is necessary at the use of brake sequence function.

(*1) Default setting values vary depending on the setup menu setting.

(*2) Default setting values depend on inverter's capacity. Refer to the instruction manual about the default setting values.

- (*3) Select the vector control in case of using brake sequence functions (output terminal functions: 68, 69).
Set $P02$ (Torque boost setting macro function) = 2 (vector control + auto-tuning), or set motor constant parameters ($F401$ to $F417$) and $P1$ (V/F control mode selection) = 3 (vector control)
- (*4) $F304$ (Dynamic braking selection) = 1 to 4 (Enabled) setting will process automatically as same as $F305$ (Overvoltage limit operation) = 1 (Disabled).
- (*5) The braking resistor with the value smaller than the minimum allowable resistance value cannot be connected.
- (*6) Set the resistance capacity suitable for specifications of connected braking resistor's capacity.
- (*7) This is one of the stall prevention functions of lift application. If the stall prevention function continues, the inverter judges that the motor has stalled and trips. Set the detection time to about 0.5 seconds.
- (*8) If brake is not active when switching forward/ reverse, set the value of Speed reference filter coefficient ($F462$) smaller little by little.

4.4 Brake sequence function

The brake sequence function is to ensure smooth operation with the motor by producing enough torque before the brake is released.

■ Starting procedure

After the run command is ON, the motor produce the torque set with $F343$. The brake release request signal is put out through the brake output terminal at the same time the torque is generated. After the brake release time set with $F345$ elapsed, the motor starts to accelerate.

■ Stopping procedure

After the run command is OFF, the operation frequency is decreased to the creeping frequency set with parameter $F346$, and delays the braking request for the creep time 1 set with $F340$ to minimize swing of the load. And then, the creeping frequency is maintained for the creep time set with $F347$ before the inverter stops.

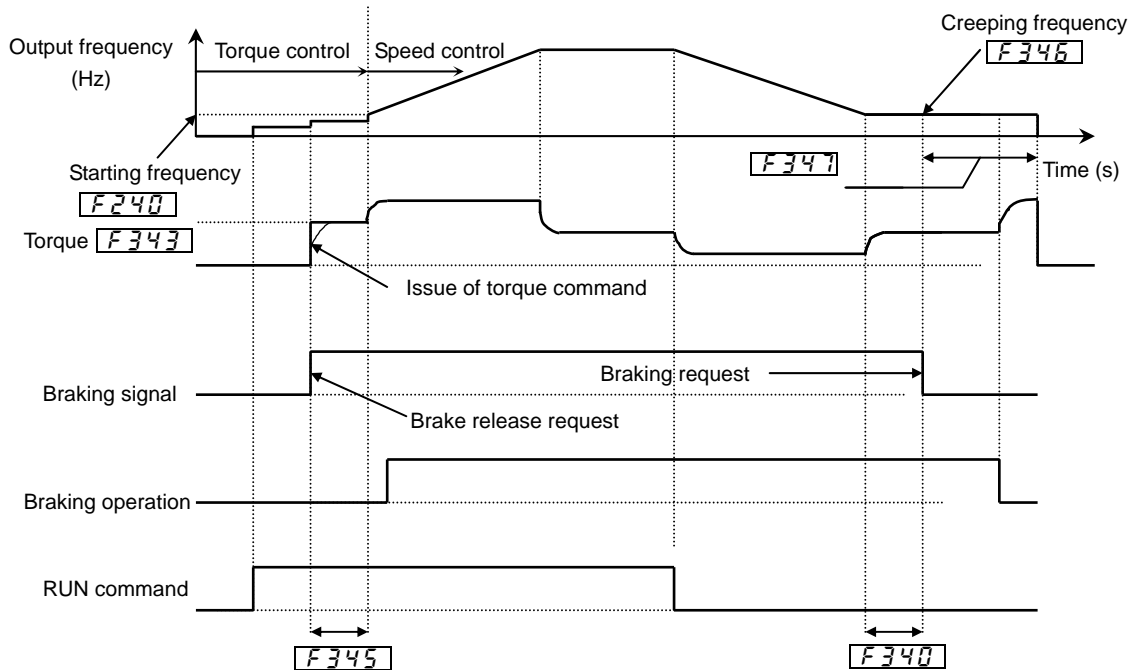

■ Small current detection

The brake release request signal is not output during $F325$ (Brake releasing waiting time) setting time after the brake release (the torque command is issued) after the run command is ON.

When $F326$ (Brake releasing small current detection level) is set, the inverter trip as low-current operation fault (UL) if the output current is $F326$ or less after a lapse of $F325$ setting time.

When $F326 = 0$, the small current detection is not active.

In case of using learning function, $F325$ setting time is not include learning time because the brake request signal is not output during $F325$ setting time.

When $F325$ and $F345$ are set, the inverter check the current for the small current detection after a lapse of $F345$ setting time if $F325 > F345$.

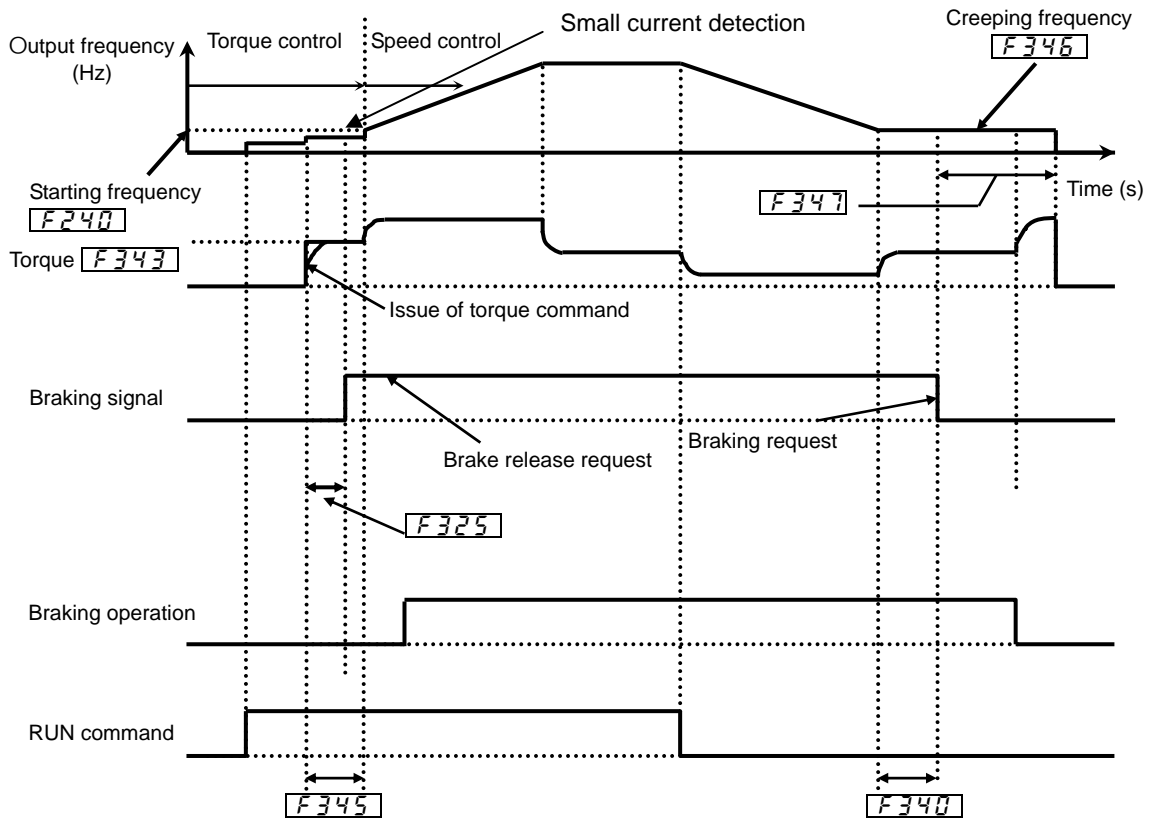

4.4.1 Parameters for brake sequence functions

Title	Functions	Setting range	Default setting value	Setting sample	Notes
<i>F325</i>	Brake releasing waiting time	0.00-2.50 (s)	0.00	0.00	
<i>F326</i>	Brake releasing small current detection level	0-100 (%)	0	0	
<i>F340</i>	Creeping time 1	0.00 - 10.00 (s)	0.00	0	
<i>F341</i>	Braking mode selection	0:Disabled 1:Forward winding up 2:Reverse winding up 3:Horizontal operation	0	1	
<i>F342</i>	Load portion torque input selection	0:Disabled 1:Terminal VIA 2:Terminal VIB 3:Terminal VIC 4: <i>F343</i>	4	4	
<i>F343</i>	Hoisting torque bias input (valid only when <i>F342</i> =4)	-250 - 250(%)	100	100	
<i>F344</i>	Lowering torque bias multiplier	0 - 100(%)	100	60	
<i>F345</i>	Brake release time	0.00 - 10.00 (s)	0.05	0.05	(*1)
<i>F346</i>	Creeping frequency	<i>F240</i> - 20.0(Hz)	3.0	3.0	(*1)
<i>F347</i>	Creeping time 2	0.00 - 10.00 (s)	0.10	0.10	(*1)
<i>F348</i>	Braking time learning function	0:Disabled 1:Learning (0 after adjustment)	0	1	

F325 : Brake releasing waiting time

The brake release request signal is not output during *F325* (Brake releasing waiting time) setting time when the brake release.

The function is disabled when *F325*=0.00.

F326 : Brake releasing small current detection level

The inverter trip as low-current operation fault (*UC*) if the output current is *F326* or less after a lapse of *F325* setting time when the brake release.

The function is disabled when *F326*=0.

F340 : Creeping time 1

Inverter suspends the braking request for the time set with *F340* to minimize swing of load.

F341 : Braking mode selection

This parameter is to select operation mode of brake sequence function.

Usually, the forward (Terminal F) operation is winding up.

F342 : Load portion torque input selection

This parameter is to set the brake releasing torque value balanced with the load torque to prevent load gap (shifts) at brake release.

Usually, set *F342* = 4, and set the fixed value to *F343* (Hoisting torque bias input) .

F343 : Hoisting torque bias input

This parameter is to set hoisting torque bias value and enabled only when *F342* = 4.

The 100% value is the motor rated torque determined by *F405* (Motor rated capacity) and *F417* (Motor rated speed).

Usually, set *F343* = 100. In case of trouble after brake learning, adjust this setting value.

F344 : Lowering torque bias multiplier

The torque bias value at brake release is set by **F342** (Load portion torque input selection). When winding down, the torque bias value is multiplied by this parameter value.

Usually, a necessary torque in winding down is decreased by squaring the mechanical efficiency.

The hoisting torque bias in winding down at 80% machine efficiency is $0.8 \times 0.8 = 0.64$ (about 60%).

Usually, set **F344** = 60 to 70.

F345 : Brake release time

The brake release request signal is output at the same time outputting the set torque after the starting signal is turned on.

After the time set with **F345** (Brake release time), the inverter accelerates.

(*1)This parameter is roughly adjusted by executing **F348** (Braking time learning function).

F346 : Creeping frequency

After run command is OFF, braking request is put out after decelerated to **F346** (Creep frequency). A standard setting of the creep frequency is about motor rated slips. For example, in case of 5% slips in 60Hz motor, the creeping frequency is "60Hz*5%=3Hz".

(*1)This parameter is roughly adjusted by executing **F348** (Braking time learning function).

F347 : Creeping time 2

After run command is OF, braking request is put out after decelerated to **F346** (Creep frequency). Then, the creeping frequency is maintained for the time set with **F347** (Creeping time 2).

(*1)This parameter is roughly adjusted by executing **F348** (Braking time learning function)

F348 : Braking time learning function

The brake learning function is executed by forward winding up operation after setting **F348** (Braking time learning function) to 1.

Braking time learning function roughly adjusts the parameters **F345** (Brake release time), **F346** (Creeping frequency), and **F347** (Creeping time 2).

■ Torque bias function (**F342** to **F344**)

With this function, the motor produces enough torque balanced with the load portion for the opposite side before the brake is released, which enables smooth start of the load.

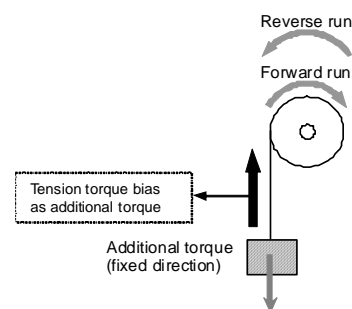

<Selection of external signals>

		F342
Voltage signals	— VIA-CC – 0-10V (0-250%)	1
	— VIB-CC – 0-±10V (-250-250%)	2
Current signals	— VIC-CC – 4(0)-20mA (0-250%)	3

4.4.2 Execution of "Brake time learning"

The brake function sets automatically the timing (torque establishment when starting) of the preliminary excitation by motor's constant value.
It is necessary to set related parameters before "brake time learning".

Before executing "brake time learning", the brake timing may not fit the load torque.
Execute "brake time learning" at no load or at light load that is 3% of rated load or less.

■ Learning function ($F348$)

This function roughly adjusts the parameters $F345$, $F346$, and $F347$ automatically.
If necessary, fine adjust the parameter setting manually.

■ Learning operation

Set parameter $F348$ to 1 and enter an operation command to start learning.

The frequency and "Hz" are displayed alternately.

Parameter $F343$ (torque) is set, the brake release timing is calculated, and parameter $F345$ (release time) is set based on the calculation result. $F346$ is calculated and set automatically based on the motor constant. At the stop of operation, $F347$ (creep time) is set.

Note 1: Learning should be performed under light-load conditions.

Note 2: If a counterweight is provided, a learning error may occur. If so, make an adjustment manually.

Note 3: Brake learning should be carried out for forward rotation if $F341$ is set to 1 (forward winding), or for reverse rotation if $F341$ is set to 2 (reverse winding).

《Notice for brake sequence function》

Note 4: For the brake sequence functions, the pre-excitation time is automatically determined by the inverter from motor-related constants.

When the VFS15S-2022PL-W is used in combination with a Toshiba 4P-2.2kW-60Hz-200V standard motor, the pre-excitation time is approximately 0.1 to 0.2 seconds.

Depending on the motor, the pre-excitation time may be prolonged.

Note 5: Select the vector control in case of using brake sequence functions.

Set $F460$ and $F462$ following to the tables described in 4.3.

Set $AU2$ (Torque boost setting macro function) = 2 (vector control + auto-tuning) or set motor constant parameters ($F401F$ to 417) and $P1$ (V/F control mode selection) = 3 (vector control).

Note 6: For checking the inverter operation by brake sequence functions, be sure to connect and run the combined motor.

As this function calculates the brake timing by detecting output current, calculation error occurs without connecting the motor.

4.4.3 Brake timing with maximum load

Confirm if there is any problem with brake timing with maximum load after completion of adjustment of brake timing at no-load (light load).

Please confirm the following items;

- Whether or not brake is released smoothly without load gap (shifts) at winding up or starting
- With or without load gap (shifts) when the brake operates?
- With or without load gap (shifts) when repeating start (run/stop)?
- With or without unusual noise from the brake at the time of start and stop.
- With or without the inverter trip at the time of start or stop.

If there is no trouble after confirmation, an adjustment of the brake function is completed.

《Useful function for adjustment》

Timing adjustment to release brake at the same time with gaining enough torque and stop after the brake is completely closed are required for lift application.

Therefore, the motor is restrained to some degree at start/stop.

Short restrained time may cause load gap (shifts). But, long restrained time increases motor current, which will cause the inverter trip.

Please use the following parameters for adjustment to confirm a peak output current.

Usually, a peak output current is about 150% of inverter's rated current.

Title	Function	Setting range	Default setting value	Setting sample	Notes
<i>F709</i>	Standard monitor hold function	0:Real time 1:Peak hold 2:Minimum hold	0	1	-
<i>F710</i>	Initial panel display selection	0 - 52	0	1	Output current
<i>F750</i>	EASY key function selection	0:Easy/standard setting mode switching function 1:Shortcut key 2:Local/remote key 3:Monitor peak /minimum hold trigger 4:- 5:-	0	3	-

The status monitor display shows "Peak hold value of output current" by the above parameter settings.

Display changes as the peak value of the output current changes by repeating start/stop.

This value is forcibly reset by pushing the "EASY" key.

4.4.4 Abnormal phenomenon and the measures

Abnormal phenomenon and the measures (adjustment item) according to load and operating condition

Load condition	Operating condition	Abnormal phenomenon	Countermeasure (adjustment item)
No-load	At start	Wind down after winding up a little when the winding down command is issued.	<ol style="list-style-type: none"> 1) Set $F 345$ (Brake release time) to short. 2) Lower the value of $F 344$ (Lowering torque bias multiplier) by 5%. 3) Lower the value of $F 343$ (Hoisting torque bias input) by 5 to 10%.
No-load or load	At start	The load falls slightly (load gap/shift) when winding up.	<ol style="list-style-type: none"> 1) Increase the torque bias value of $F 342$ (Load portion torque input selection) and $F 343$ (Hoisting torque bias input) by 10 to 20%.
No-load or load	At start or stop	The load falls slightly (load gap/shift) by repeating start/stop (inching) frequently at winding up.	<ol style="list-style-type: none"> 1) Set $F 345$ (Brake release time) to short.
No-load or load	At switching forward/reverse	Brake is not active when switching forward/ reverse.	<ol style="list-style-type: none"> 1) Lower the value of $F 452$ (Speed reference filter coefficient) by 5

«Notice of adjustment»

When adjusting $F 345$ (Brake release time) and $F 347$ (Creeping time 2), change the value little by little.

A large value of change causes large time lag between when the brake is released and when the enough torque is produced, which may result in fall of the load.